



OXSA

OXSA ROAD - DIAGONAL PLOW CHOOSSED BY PROFESSIONALS!



OXSA
ROAD 3600
Powered by KARITEK

OXSA ROAD - DIAGONAL PLOW

The OXSA product family is growing with road maintenance products. OXSA ROAD Diagonal Plows belongs to the royal category of road maintenance. The diagonal plow is efficient thanks to its finely honed features and structures like modern housing frame that makes it strong and agile to move.

The starting point for ROAD - diagonal plow has been their suitability for professional contracting use and the varying conditions in Finland. The ploughs development work has been done since 2004 and its features have been refined to their peak.

ROAD series plow have everything you need. As a standard, plows have a hydraulically released blade with a pressure accumulator for safety, a optimised wing that throws even at low speeds and LED lights. The wear blade is a standard 305 mm pitch, so all blade options are available for the diagonal plow depending on the work you need.

Modern manufacturing technology

Thanks to long product development and modern design and manufacturing methods, the body of the diagonal plow has been made very tensile, yet agile and balanced to move. Thanks to the housing structures, the torsional stiffness is high and at the same time unnecessary weight is removed, which reduces the power requirement of the machine. HB400 special steel is used in areas in the frame that need durability and HB500 special steel is used in areas prone to hard wear, such as the blade.

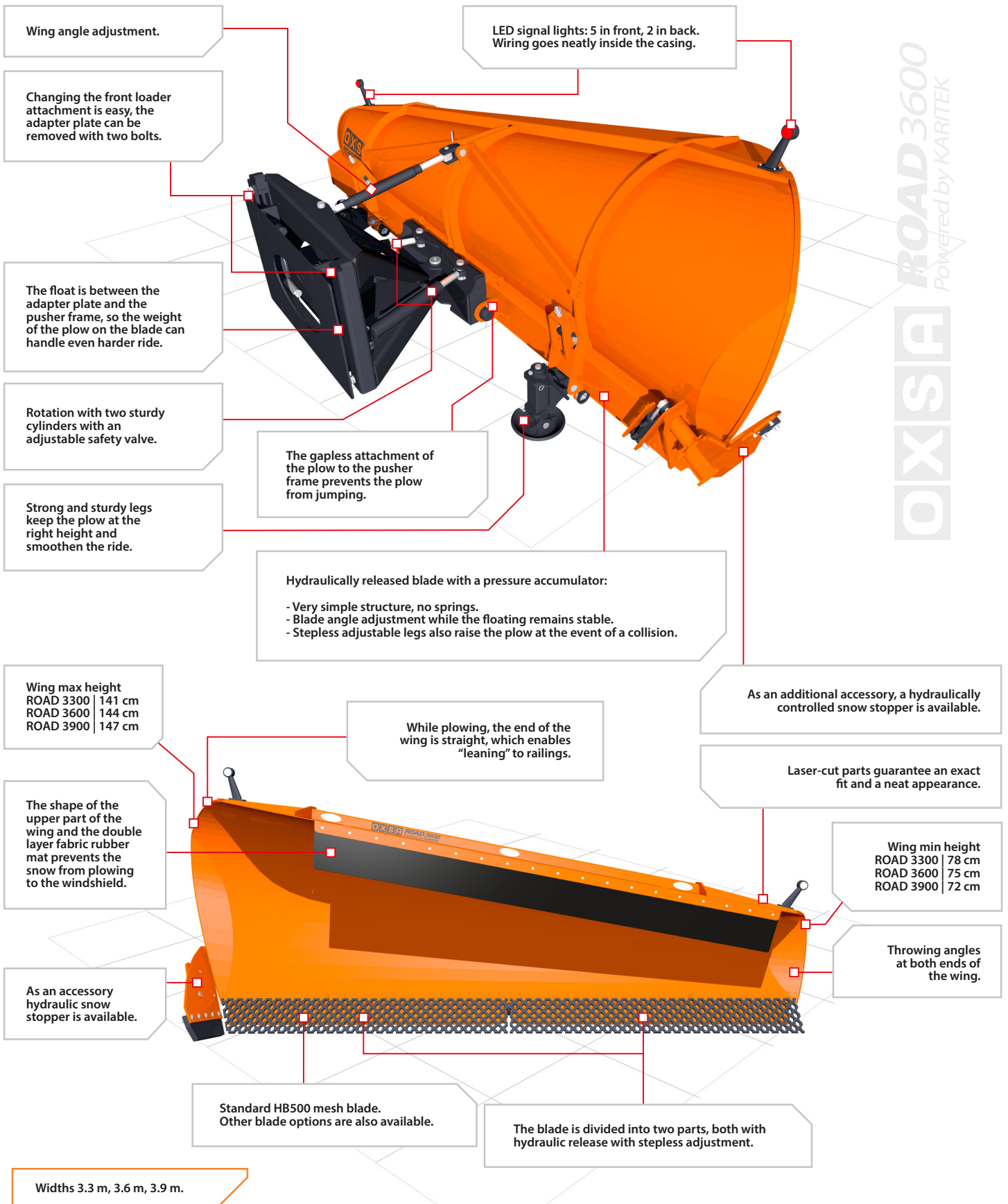

OXSA ROAD Accessories

- Snow stopper
- Smooth blade
- Tooth blade
- Carbine blade



OXSA ROAD

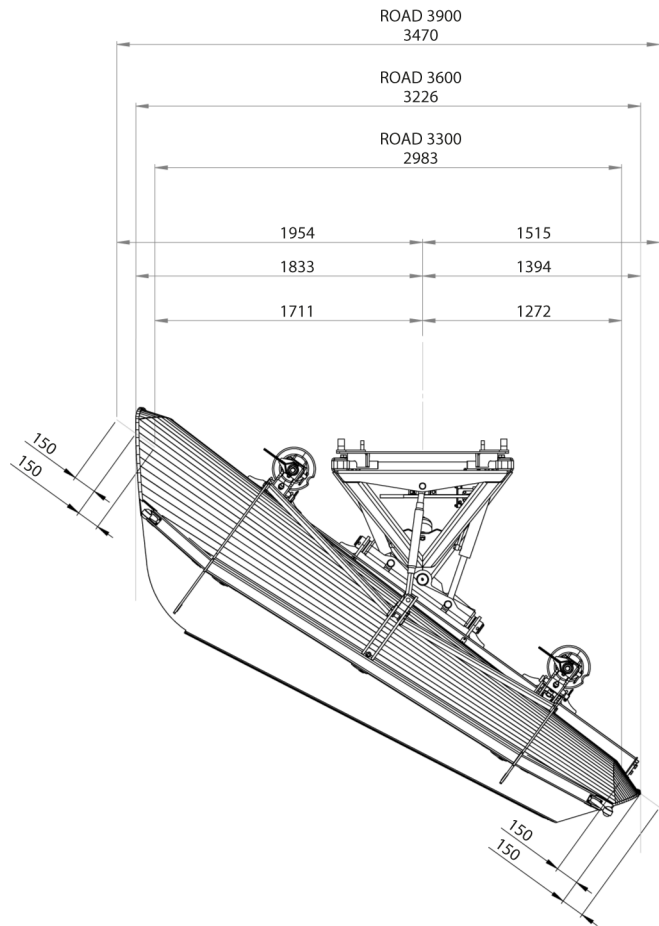

DIAGONAL PLOW MODEL			OXSA ROAD		
			3300	3600	3900
Working width	(mm)	3300	3600	3900	
Height, min	(mm)	782	752	722	
Height, max	(mm)	1412	1441	1471	
Edge dimensions, straight wing	(mm)	3744	4044	4344	
Edge dimensions, rotated wing	(mm)	2983	3226	3470	
Plow wing turning angle	(deg)	48	48	48	
Weight	(kg)	1100	1150	1200	
Blade spring / float		Hydraulic, stepless adjustment	Hydraulic, stepless adjustment	Hydraulic, stepless adjustment	
Lights, LED	front/back (pieces)	2 white + 3 yellow / 2 red	2 white + 3 yellow / 2 red	2 white + 3 yellow / 2 red	

Closest Retailer

www.oxsa.fi

